

**FLANGE COMPETENCY TESTING PROGRAM**  
GENERAL DESCRIPTION



**PREPARED BY:**

Peter Dijkgraaf

E-mail : [peter@dijkgraaf-support.com](mailto:peter@dijkgraaf-support.com)

Mobile : +31 6 51 38 59 67

Update : January 2020

**Dijkgraaf Support B.V.**

*Specialized in Flange Integrity Management Training & Flange Assembly Competency Testing*  
*European certified training institute by TQ Cert in accordance with CEN 1591-4:2013*



### Content

- 01) Introduction
- 02) Flange management guidelines
- 03) Flange competency test rig
- 04) Flange competency test – test elements
- 05) Competency test results
- 06) Flange instruction



### Appendixes

- Appendix (I)** : Competency test Scorecard (practical example – German language)
- Appendix (II)** : Test sheet 'Flange Misalignment' (practical example – German language)
- Appendix (III)** : Instruction card: competency test at test skid (examples in different languages)

### 01) Introduction

A bolted flange connection is in our industry one of the most critical sealing techniques with respect to the integrity of the process units. A failure of the bolted flange connection can have severe consequences with respect to safety, health, environment, cost and 'license to operate'.

In our European industry the experience and competency of flange bolting technicians is in many cases inadequate. To improve, the European norm EN 1591-4 'Qualification of personnel competency' is designed and adapted in 2013 by most European member states.

In the Netherlands, it is a legal obligation for contractors working in the petrochemical industry (as part of their VCA certificate) that their flange bolting technicians are certified according the WF(pr). In practice it appears that this WF(pr) certificate gives too little guarantee with respect to assure the required minimum level for flange bolting competency.

Especially during unit shutdowns (turnarounds), large numbers of flange bolting technicians are employed without any capability check with respect to personal experience and competency. Upfront, a competency test is desired to determine if the bolting technicians meet the minimum required level. This flange competency test can be compared to a 'welding test', which is required for a welder to prove his welding skills before he starts his welding job.

The flange competency test skid is designed with the purpose of:

- Testing the skills and competency of flange bolting technicians.
- Training tool, used during practical exercises as part of the flange integrity training.





### 02) Flange management guidelines

The two most essential guidelines, as used in our industry are:

- EN1591-4 Flanges and their joints – Part 4:  
*‘Qualification of personnel competency in the assembly of the bolted connections of critical service pressurized systems’.*
- PCC1-2013 *‘Guidelines for Pressure Boundary Bolted Flange Joint Assembly’.*

In practice, a flange certificate doesn’t give sufficient guarantee that the bolting technician meets the minimum required competency level. One of the reasons is that the principles, as laid down in the guidelines, are not sufficiently integrated in the training and certification process for the bolting technicians.

#### [Related Information](#)

##### **Alignment of flanged joints**

**ASME PCC-1-2010**  
(Revision of ASME PCC-1-2000)

Proper alignment of all joint members is the essential element of flange joint assembly. It results in maximum sealing surface contact, maximum opportunity for uniform and design-level gasket loading,

##### Table 2: Torque increments for Legacy Cross-Pattern Tightening Using a Single Tool

Install: Hand tighten, the ‘snug up’ to 15. [Nm] to 30 [Nm] (not exceed 20% of Target Torque).

Check flange gap around circumference for uniformity.

If the gap around the circumference is not reasonably uniform, make the appropriate adjustments by selective tightening before proceeding.

The PCC1 guideline identifies ‘flange misalignment’ as an essential element of flange joint assembly. In most training modules, this aspect is not sufficiently explained and exercised.

The flange training and competency testing as defined by Dijkgraaf Support is based on the guidelines of the PCC1 and the EN1591-4. A very important part of this is the practical exercise on the flange assembly test skid. This is in line with the PCC1 requirement that for qualification, the bolting technician should show his practical skills by assembling a flange joint which include all practical aspects (such as flange misalignment).

#### [Related Information](#)

##### **Appendix A: Training and Qualification of bolted joint Personnel**

**ASME PCC-1-2013**  
(Revision of ASME PCC-1-2010)

##### A-2.4 Practical Examination

The Qualified Bolting Specialist shall demonstrate his or her understanding in the assembly of bolted joints by taking part in at least one of the following range of bolted joint practical demonstrations.

The demonstrations are designed to highlight significant aspects of the training curriculum and are to be performed in the presence, and to the satisfaction, of a Qualified Bolting Specialist Instructor.

In addition, a practical examination of each candidate, requiring the assembly of at least two joints, shall be required.

The criteria for pass / fail shall include measurement of the obtained gasket deformation and bolt load variation and shall be assessed by a Qualified Bolting Specialist Instructor. The examination shall include all aspects of joint quality assurance that have been taught in the course.

As part of the practical exercise for qualification, the bolt load and the bolt load scatter is measured to judge the quality of the joint and so the competency of the bolting technician.

### 03) Flange competency test rig

In line with the PCC1 guideline, a competency test rig is designed to test the bolting technician on the most essential elements of flange assembly with a degree of complexity that simulates the reality in practice.

#### Design principle

- A flange pair is constructed using a flange fixation bar (European patent: 3181974) that is calculated by detailed finite element calculations as such that the actual stiffness of an 8" piping system is simulated.
- The flange pair is positioned as such, that it has built-in misalignments (Angular, gap and lateral).

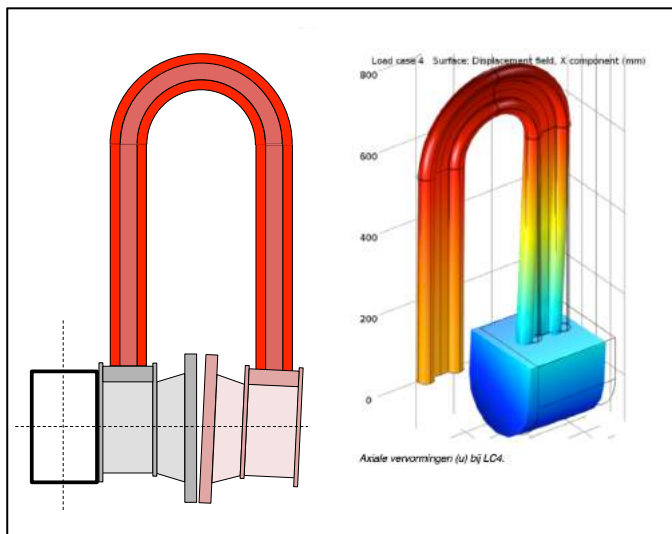

*Flange pair with flange fixation bar (incl. FEM plot)*

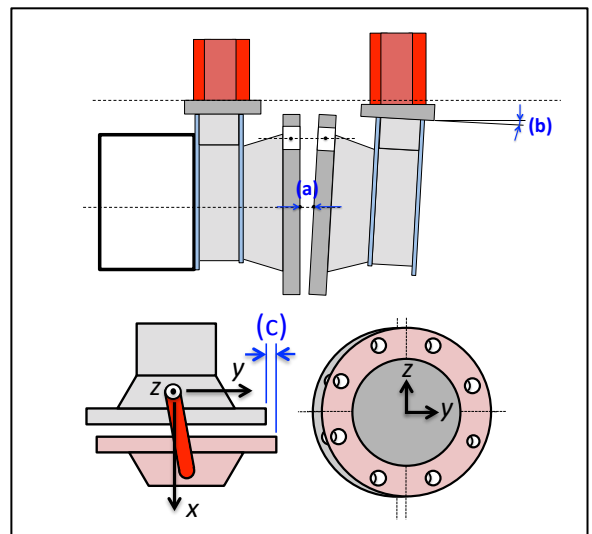

*Flange built-in misalignments*



*Competency test with 18 work places (alternatives: 6 or 12 work places)*

### 04) Flange competency test – test elements

The test elements in the competency test are selected as such that within a limited timeframe of 2 hours, a realistic assessment of the experience and competency of the bolting technician is achieved.

#### Assessment test items, such as:

- Inspection of tools.
- Selection / inspection gasket.
- Selection / inspection bolts / nuts / washers.
- Usage of alignment tools.
- Usage of caliper.
- Correct position nut / stud-bolts / washer.
- Method to 'fit' the flange (according PPC-1):  
=> Measure 'break lose' moments.
- Report bolting technician deviations y/n?
- Tightening sequence (cross- / clock wise):  
=> Measure 'break lose' moments.
- Rewind hand torque wrench after completion.

In this chapter, some of the most essential test elements are described.

For all test elements, [see appendix \(I\): total scorecard 'competency testing' \(example in German language\)](#)

#### Test element (01A): measurement of flange gap with caliper

- For this test, sets of 3" 150# flanges have been manufactured.
  - Each set has its own unique misalignment, to prevent looking away to other candidates during the test.



*3" 150# flange assemblies to test the competency of measuring the flange gaps*



*Cabins for instruction and gap measurement testing*



# FLANGE COMPETENCY TESTING PROGRAM

## GENERAL DESCRIPTION



*Bolting technicians measuring the flange gaps with a caliper*

# FLANGE COMPETENCY TESTING PROGRAM

## GENERAL DESCRIPTION



**Test element (01b):** interpretation of the gap measurements – flange yes/no within rejection criteria

- The rejection criteria are given on the exam test sheet.  
[See appendix \(II\): Exam test sheet 'flange misalignment'](#) (example – German language)

**Test element (02a):** skilful use of hand torque wrench – measuring accuracy with setting at 100. [Nm]

- Before this test, mostly an instruction has been given about the use of a hand torque wrench.



*Computer read-out  
actual applied torque*

*Hand torqueing with 100. [Nm] at calibration device.*





# FLANGE COMPETENCY TESTING PROGRAM

## GENERAL DESCRIPTION



### Competency test at test rig

For the competency test at the test skid, instruction cards in different languages are available.

[See appendix \(III\): Instruction card competency test headings in different languages.](#)

### Test element (05 / 06): using centring pins

- The use of centring pins is essential if the lateral displacement is above the maximum allowable limit.
  - If the centring pins are not used, there is a risk of damaging the bolt thread:  
=> higher friction => lower bolt load.



### [Related Information](#)

General industry standard	
Nominal Pipe Diameter	Maximum lateral misalignment
D ≤ 4. [inch]	2. [mm]
D > 4. [inch]	3. [mm]

Lateral misalignment criteria

**ASME PCC-1-2013**  
(Revision of ASME PCC-1-2010)

According to the norm, all bolting technicians should use centring pins during the test.

### Test element (08): selecting the correct type of gasket (specification, new and undamaged)

- The bolting technicians have to select the correct gasket out of the 4 gaskets, hanging on the hook:
  - 1 x wrong specification, 1x wrong thickness, 1x used / old, 1 x correct.

### [Related Information](#)

**Gasket handling, preparation and installation**

- Use of a single, new (not used or damaged) gasket for final installation.
- Final inspection of gasket seal surface and gasket dimensions / type and damage.

**ASME PCC-1-2013**  
(Revision of ASME PCC-1-2010)

According to the norm, all bolting technicians should pay attention to select the correct gasket.

### Test element (09): studbolt material identification marks all to the same side to simplify inspection

- The bolting technicians have to install the studbolts as such that the material code is to the front side.

### [Related Information](#)

**Identification of correct joint components**

- Installation of bolts and studs such that marked ends are all on same side of joint, with nut identification marks facing out, to facilitate inspection.

**ASME PCC-1-2013**  
(Revision of ASME PCC-1-2010)

According to the norm, all bolting technicians should install the material marks to the same side.

**Test element (10/11):** selecting the correct bolts and nuts (correct material specification and undamaged)

- The bolting technicians have to select the correct bolts and nuts:
  - In each toolbox, bolts and nuts of the wrong materials are added.

[Related Information](#)

<p><b>Bolt / Nut Specification</b></p> <ul style="list-style-type: none"> <li>- Verify compliance with bolt and nut specifications.</li> </ul>	<p><b>ASME PCC-1-2013</b> (Revision of ASME PCC-1-2010)</p>
--	---

According to the norm, all bolting technicians should pay attention to the bolts / nuts selection.

**Test element (15):** fitting of flange with angular misalignment – too high misalignment => stop work => report

A crucial step before the phase of tightening of the joint is the step of 'fitting'.

[Related Information](#)

<p><b>5 Alignment of flanged joints</b></p> <p>Proper alignment of all joint members is the essential element of flange joint assembly. It results in maximum sealing surface contact, maximum opportunity for uniform and design-level gasket loading,</p> <p><u>Table 2: Torque increments for Legacy Cross-Pattern Tightening Using a Single Tool</u></p> <p>Install: Hand tighten, then 'snug up' to 15. [Nm] to 30 [Nm] (not exceed 20% of Target Torque).                  Check flange gap around circumference for uniformity.                  If the gap around the circumference is not reasonably uniform, make the appropriate adjustments by selective tightening before proceeding.</p>	<p><b>ASME PCC-1-2013</b> (Revision of ASME PCC-1-2010)</p>
--	---

The step of 'fitting' is well defined in the PCC1 guideline. After fitting the flange with 20-30% of the final torque, the angular misalignment needs to be below the maximum gap tolerance.

The risk of assembling a flange with a too high angular misalignment is that, even if the bolt forces are well applied, the gasket compression is insufficient. A far too low gasket compression can be identified during the pressure test. But mostly a low gasket compression results in a flange leakage after start-up due to relaxation of the joint under operational conditions.

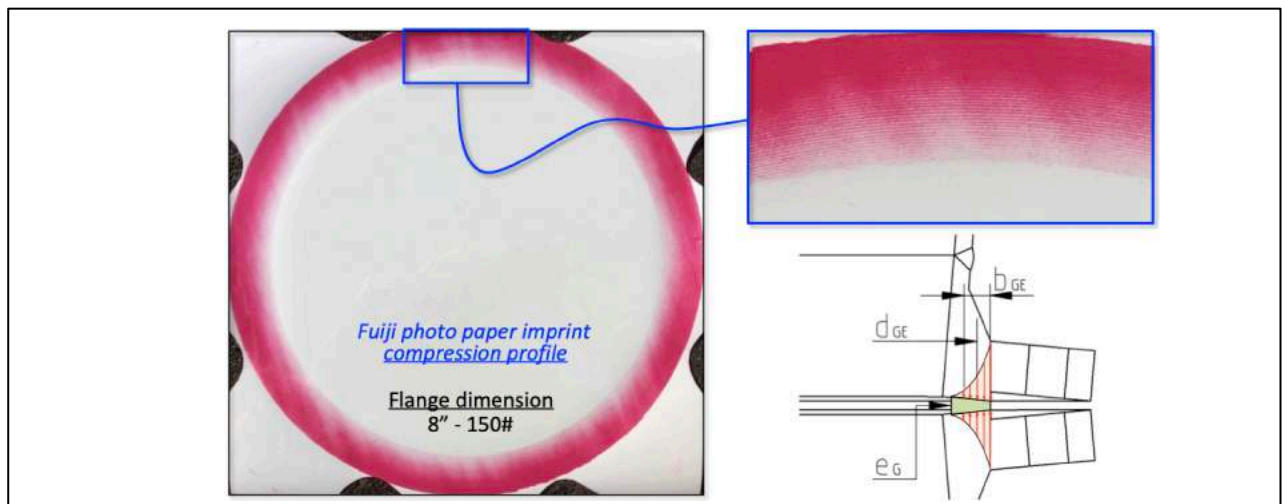

*Uniform gasket compression profile of a flange without flange misalignment*



If a flange has a too high level of angular misalignment, a too large part of the bolt forces is used to bring the flange in parallel position and a too low part of the bolt forces is effectively applied to compress the gasket.

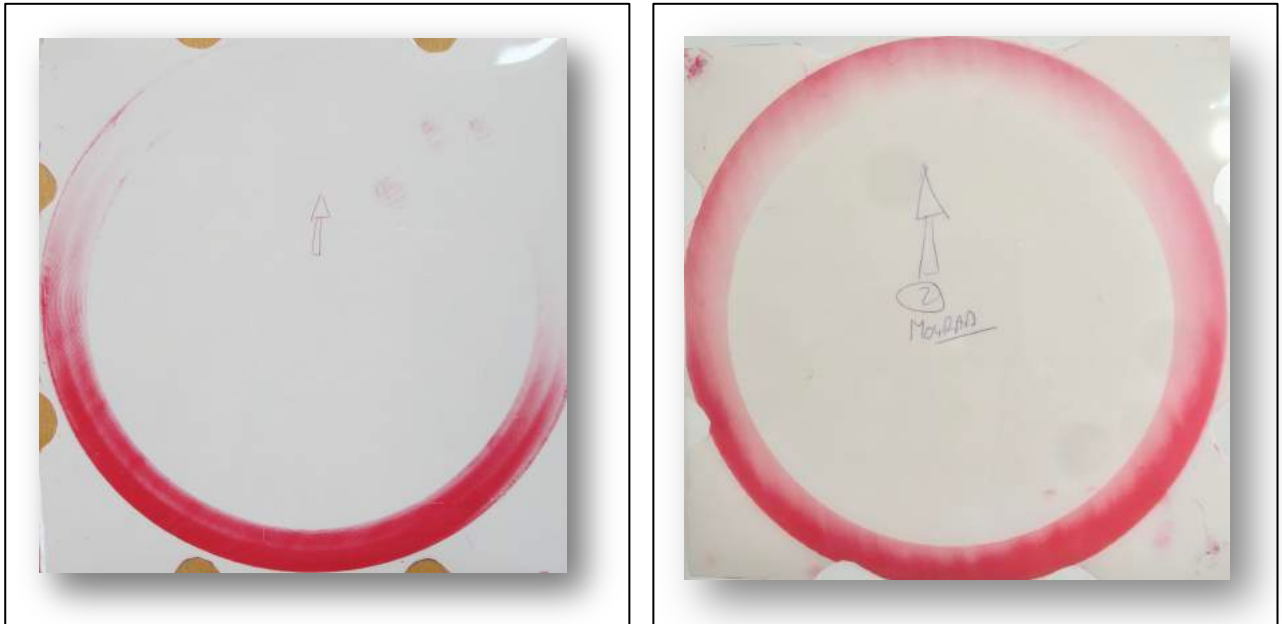

*Practical examples of a non uniform gasket compression profile as a result of too high angular misalignment*

In **test element (15)** is checked if the angular gap is interpreted correctly.

The flanges of the test rig are all far outside the maximum allowable angular misalignment. During the competency test, all the bolters should stop the work after 'fitting' and report to the assessor that the flange misalignment is outside tolerance.

- Unfortunately, most bolters are not aware of the risk due to high angular misalignment and continue the flange assembly without reporting. This creates a low integrity joint with a high risk for flange leakage (see compression profiles as shown in this section).

**Test element (17a / 17b):** accuracy of bolting technician to apply 60 [Nm] with hand wrench during 'fitting'

The PCC1 guideline is rather strict by the requirement to apply maximum 20% torque during 'fitting'. General industry standard is that the maximum allowable torque for fitting is around 30% of the final torque.

After 'fitting', the break-loose moments are measured, using an electronic hand torque wrench.

- Experienced bolting technicians start to tighten all 4 bolts (with approx. the same bolt force) around the largest gap (top bolts at the test rig) of the flange, to bring the flange pair in parallel position.
- Experienced bolting technicians take care that the 4 bolts around the smallest opening (lower bolts at the test rig) have sufficient clearance to enable the flange pair to rotate into parallel position.
  - In practice, the highest break-loose moments are often measured at the lower bolts. This can be explained by the fact that during 'fitting', the lower bolts don't have sufficient clearance.
  - While tightening the upper bolts, additional bolt force is introduced in the lower bolts if there is no clearance.

### Test element (19): bolt load scatter after flange assembling

High quality flange assembly will result in a uniform gasket compression profile. One of critical enablers is that all the bolts are tightened with equal bolt torque.

By means of an electrical hand torque wrench, the break-loose moments of all the bolts are measured. The difference between the highest and lowest break-loose moment is called the bolt load scatter:

- Due to several types of deviations, good practice is that the bolt load scatter is in the range of: (-5% up to +20%) around the final target torque.
- A high bolt load scatter often is a result of:
  - Wrong usage of the hand torque wrench (too much 'pushing' or wrong direction).
  - Not following the correct tightening steps (e.g. not applying the final 'clock around' tightening step).



*Break-loose measurements by assessor using an electronic hand torque wrench*



### 05) Competency test results

The assessment criteria of the outcome of the various test elements are defined in consultation with the plant owner. On average, (10% -15%) of the tested bolting technicians are not passing the test.

#### Main objective of the competence test:

By rejecting a small group of bolting technicians with a far too low level of experience and competency, the integrity risk during operations due to flange failures is significantly reduced!

#### Practical example: test result implementation

The contractors who passed the test, received a helmet sticker:

- Failed : no helmet sticker => not allowed to assembly flanges.
- Average : helmet sticker => work on low- and medium critical flanges.
- Good : helmet sticker => work on high critical flanges.  
authorised to sign-off the flange protocols.



### 06) Flange instruction

As part of the competency-testing program, it is an option to give a short flange instruction to the contractor supervisors:

- Specific items (such as the company flange procedure) can be instructed.
- Following the 'train the trainer' concept, the supervisors can instruct their own flange bolting technicians:
  - In case the bolters don't speak the English / German language, the supervisors can explain the headlines of the flange procedure in their own native language.



*Two-hour instruction for the contractor supervisors on the company flange procedure by the assessor*

Appendix (I)  
Competency test Scorecard (practical example – German language)

Arbeitsprobe der Flanschenmonteure											
Datum :											
Zeit :											
Auftragnehmer :											
Vorname des Monteurs =>											
Nummer des Monteurs =>		10	11	12	13	14	15	16	17	18	
1a	Spaltmaße - ablesen messeschieber : richtig / falsch *	+ -	-	+ -	+	-	+ -	-	+	+	
1b	Anwendung Toleranzen Spaltmaße Tabelle : richtig / falsch *	+	-	-	+	-	+	+	+	+	
2a	Test Handdrehmomentschlüssel: 100. [Nm] *	102	120	98	108	240	195	219	121	137	
2b	Wiederholung bei extremen Abweichungen: Test Handdrehmomentschlüssel: 100. [Nm]										
3	LMRA: Werkzeugkiste beiseite gelegt? *	+	-	+	+	-	+	-	+	+	
4	Verwendung von persönlicher Schutzausrüstung? *	-	-	-	-	-	-	-	-	-	
5	Einsetzen Passdorne <u>vor</u> dem verwendung Schrauben? *	+	-	-	+	+	+	+	+	+	
6	Gute Positionierung Passdorne?	+	-	-	+	+	+	+	+	-	
7	Einsetzen Schrauben <u>nach</u> dem verwendung Passdorne?	+	+	+	+	+	+	+	+	+	
8	Dichtung: korrekte Spezifikation - Dicke - neue Kondition? *	-	-	+	-	-	-	-	+	-	
9	Bolzen: mit Werkstoffmarkierung in derselben Richtung?	-	-	-	-	-	-	-	+	-	
10	Bolzen: Spezifikation nach Anforderung? *	+	-	-	+	-	+	-	+	-	
11	Muttern: Spezifikation nach Anforderung? *	+	-	+	+	+	+	-	+	-	
12	Muttern: Auflagefläche nach unten? *	+	-	+	+	+	+	+	+	-	
13	Unterlegscheiben: alle Scheiben montiert? *	+	+	+	+	+	+	+	+	+	
14	Unterlegscheiben: Auflagefläche nach oben?	+	-	+	+	+	+	+	+	+	
15	Mängelanzeige - Arbeit stoppen? * Material Qualität - Flansch außerhalb Toleranzbereich..... *	-	-	-	-	-	-	-	+	+	
16	Einbau: minimaler Spalt zwischen Dichtung - Dichtfläche? *	-	-	-	-	+	-	-	+	+	
17a	Einbau: 'Break lose' Drehmomentmessung Bereich: Bolzen an der <b>Oberseite</b> des Flansches [Nm]	Minimum	39	6	60	57	41	0	0	6	26
		Maximum	76	13	77	75	153	27	148	16	228
17b	Einbau: 'Break lose' Drehmomentmessung Bereich: Bolzen an der <b>Unterseite</b> des Flansches [Nm]	Minimum	48	9	82	53	76	1	152	0	66
		Maximum	74	44	147	64	119	36	246	28	144
18	Montage: Überkreuz - Uhrzeigersinn Anziehen: Schritten 40% - 70% - 100% : Korrekte Montage? *	+	-	+	+	+	+	+	+	+	
19	'Break lose' Drehmomentmessung: Höchstmaß	276	242	229	232	276	247	264	238	245	
	'Break lose' Drehmomentmessung: niedrigstes Maß	175	176	196	202	152	220	184	187	203	
20	Rückspul des des Drehmomentschlüssels? *	-	-	-	+	-	-	+	+	-	
21	Gesamteindruck des Monteurs: Langsam, Unsicher, keine Erfahrung, .....	+ -	-	+ -	+ -	-	+ -	+	+	+ -	
Prüfungsbewertung: (+) (±) (-)		+ -	-	+ -	+ -	-	+ -	+ -	+ -	+ -	
Bemerkungen		* generell nicht zu gebrauchen!									



**Appendix (II)**

Test sheet 'Flange Misalignment' (practical example – German language)



**ÜBUNG: MONTAGETOLERANZ**  
**KOMPETENZTEST FLANSCHMONTEURE**



**In Großbuchstaben ausfüllen**

Vorname : \_\_\_\_\_ Datum : 27.8.2018  
 Nachname : \_\_\_\_\_ Zeit : 11:00  
 Firma : \_\_\_\_\_ Nummer : 14

**ÜBUNG: MONTAGETOLERANZ**

Unterschrift : \_\_\_\_\_

Flanschverbindungen müssen möglichst spannungsfrei montiert werden, da durch Zusatzkräfte die Dichtheit beeinträchtigt werden kann. Die Parallelität des Flansches muß innerhalb der Ausschlußkriterium liegen.

Auf dem Tisch steht ein Flansch, der soeben montiert wurde: ASME: 3 Zoll 150#

Bei Abweichungen der Planparallelität gelten die maximal zulässigen Toleranzen aus **Tabelle: Toleranzen Spaltmaße**

Nennweite		Max. zulässige Toleranz [ mm ]
DIN	ASME	
25	1"	0,2
32	1 ½"	0,3
40	1 ¾"	0,3
50	2"	0,4
65	2 ½"	0,5
80	3"	0,6
100	4"	0,8

**AUFGABE**

- Messen** Sie die K-Werte (Spaltmaße): K1, K2, K3 und K4.
- Berechnen** Sie die : (K1-K3) und (K2-K4).
- Schreiben** Sie die Antworten in der folgenden Tabelle auf:

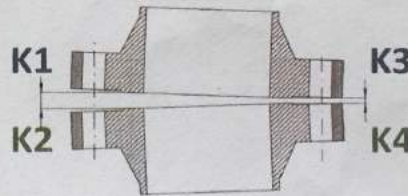

**Ist der Flansch akzeptabel?**

Befinden sich die gemessenen Werte innerhalb des Toleranzbereiches?

















Spaltmaße [mm]	Planparallelität [mm]
K1 = <u>5,3</u>	(K1-K3) = <u>5,5</u>
K2 = <u>5,5</u>	(K2-K4) = <u>5,5</u>
K3 = <u>5,5</u>	
K4 = <u>4,5</u>	

**Markieren Sie die richtige Antwort**

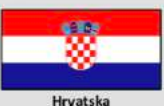
Akzeptabel	Inakzeptabel
<input checked="" type="checkbox"/>	<input type="checkbox"/>

**Appendix (III)**

Instruction card: competency test at test skid – examples in different languages

 Deutsch	<b>ANLEITUNGSKARTE</b> <b>KOMPETENZTEST FLANSCHMONTEURE</b>	
 English	<b>INSTRUCTION CARD</b> <b>COMPETENCY TEST FLANGE FITTERS</b>	
 Italiano	<b>SCHEDA ISTRUZIONI</b> <b>TECNICI ADDETTI AL SERRAGGIO FLANGE</b>	
 Türkçe	<b>İŞ TALİMATNAMESİ</b> <b>FLANŞ MONTAJCILARI - YETKİNLİK TESTİNİN</b>	
 Nederlands	<b>INSTRUCTIE KAART</b> <b>COMPETENTIE TEST FLENSMONTEURS</b>	
 Hrvatska (Croatia)	<b>VODIČ KARTA</b> <b>KOMPETENTNI TEST MONTAŽE PRIRUBNICE</b>	
 Magyar (Hungary)	<b>ÚTMUTATÓ KÁRTYA</b> <b>TUDÁSTESZT KARIMA SZERELÉS</b>	
 Polski	<b>KARTA INSTRUKCYJNA</b> <b>TESTU KOMPETENCJI POŁĄCZENIA KOLNIERZOWE</b>	
 Português	<b>FICHA DE INSTRUÇÕES</b> <b>TESTE DE COMPETÊNCIA INSTALADORES DE FLANGES</b>	